



## VODIČ ZA POVRAT

**OK TRUCKS**  
PRE-OWNED VEHICLES CERTIFIED BY **IVECO**

**IVECO**  
Your partner for sustainable transport



## UVOD

Poštovani kupče,

ovaj katalog oštećenja namijenjen je za vašu pripremu za povrat kamiona IVECO kada istekne razdoblje upotrebe.

Vraćena vozila moraju odgovarati svom originalnom opisu, posebice kada se radi o dodatnim opcijama, dodatnoj i standardnoj opremi. Osim toga, vozila moraju biti opremljena jedino dijelovima koje proizvođač preporučuje.

Navedeni primjeri ne prikazuju samo najčešće znakove istrošenosti prouzročene uobičajenom upotrebom vozila, već i najčešće vrste oštećenja nastala nepravilnom upotrebom.

Tragovi istrošenosti popraćeni zelenim simbolom na sljedećim stranicama u pravilu ne dovode do naknada i ne podliježu dodatnim troškovima po pitanju završetka dijelova ugovora.

Neprihvatljiva oštećenja istaknuta su crvenim simbolom. Sva su oštećenja detaljno obrađena u izvješću s procjenom koje naručuje tvrtka Iveco i provodi se tijekom procjene svih vraćenih vozila. Kriteriji za procjenu oštećenja navedeni su u ovom dokumentu.

Ovaj katalog oštećenja dostupan je i može mu se pristupiti na [www.benussi-cr.oktrucks.com](http://www.benussi-cr.oktrucks.com). Nadamo se da ćemo moći surađivati i želimo vam sigurno putovanje!

Vaš tim IVECO

## UVJETI POVRATA

### MJESTO POVRATA

Vozila se vraćaju na skladišta navedena u protokolu koji su strane potpisale. Prijevoznik prenositelja mora se pridržavati pravila prijema skladištara.

### OPĆI UVJETI ZA VOZILA

Svako se vozilo mora koje se vraća mora ispunjavati sljedeće uvjete:

- u radnom stanju, crvena kontrolna svjetla upozorenja neispravnosti za glavne elemente vozila isključena (ne uključuje narančasta kontrolna svjetla upozorenja)
- s dovoljnom količinom goriva, kontrolno svjetlo upozorenja na gorivo isključeno
- mora se moću potpuno sigurno upotrebljavati za prijevoz cestom, sigurnosni uređaji trebaju biti u savršenom stanju (npr. me, a neispravnih kočnica, gume nisu istrošene do okvira)
- pregledana u skladu s uvjetima održavanja koje je proizvođač postavio
- čista izvana i iznutra da bi se mogle procijeniti naknade za obnavljanje
- otvori moraju biti savršeno zabrtvljeni tako da je vozilo vodonepropusno
- ne smiju postojati oštećenje konstrukcije (neoštećeni plašt i stražnji krila, prostor krova), ne smiju postojati tragovi bilo kakvog poravnavanja konstrukcije ili rangiranja VE
- prilikom povrata mora imati svu originalni opremu i značajke, naknadna ugradnja dijelova koji se mogu skinuti može se odbiti prema protokolu
- Postavite samo dijelove koje proizvođač preporučuje
- za vozilo ne smiju postojati izvješća o krađi
- komplet gumba mora biti u skladu s normama proizvođača

Ako prijava ne uspije ili se ovo ne može opravdati, vozilo se može odbiti i/ili naplatiti naknade prema uvjetima navedenim u protokolu koji su strane potpisale.

## PREGLED VOZILA

### IDENTIFIKACIJA

Vozilo se identificira očitavanjem, modela, broja šasije (cijeli VIN), registracijskog broja i kilometraže. Dodatne informacije odnose na prisutnost sljedećih dijelova:

- dodatna oprema i dijelovi koji se mogu skinuti ovisno o opremi ili modelu vozila.  
Primjer: dodatna sjedala, podne obloge, pokrov prtljage, mreža, štitnik za vjetar itd.
- rezervni kotači i alat za zamjenu/ponovno postavljanje kotača.  
Primjer: dizalica, komplet alata, komplet za popravak ili komplet za napuhavanje i sve što se isporučuje s vozilom.
- Dijelovi koji se mogu skinuti za funkcije navođenja vozila/video/audio.  
Primjer: SD kartica, CD-ROM, telefon i sve što je navedeno da je početno isporučeno s vozilom i fizički vraćeno s vozilom.
- rezervni ključevi i kartice za otvaranje vozila.
- korisnički priručnici i knjižice održavanja.

Postupak povrata određenih gore navedenih dijelova opisan je protokolu koji su strane potpisale. Osoba koja obavlja procjenu te će značajke uzeti u obzir prilikom provjere vozila kao i ured odjela za procjenu troškova prilikom izrade procjene.



## TEHNIČKE DUŽNOSTI

Pregled koji se obavlja na karoseriji vozila statičan je. Obavit će se na skladištu pod uvjetima koje su strane dogovorile.

Tehničar utvrđuje oštećenja pomoću svjetlosti pod malim kutom. Procjenitelj će utvrditi iskrivljenja, kvarove, ogrebotine, udubljenja, krhotine, koroziju, dijelove koji nedostaju i koji su u kvaru te pogrešna poravnanja. Laka komercijalna vozila (LCV): Zabilježeno oštećenje je ono koji se vidi s prednje strane.



## VRSTA OTKRIVENOG OŠTEĆENJA

Otkriveno oštećenje bilježi se prema svojoj naravi: krhotine, ogrebotine, udubljenja, puknuti dijelovi, dijelovi koji nedostaju, kvarovi itd.

## OPIS OTKRIVENOG OŠTEĆENJA

Oštećenje se otkriva i opisuje ovisi o njegovoj veličini i broju. Može se procijeniti, navesti samo kao napomena ili ne i zabilježiti ovisno o kriterijima u nastavku.

## VRSTA POPRAVKA

- Fiksna cijena po satu: čišćenje, zazor, popravak SR, poliranje itd.
- Vrijeme utrošeno na radovima na karoseriji ovisno o opsegu oštećenja i odabranim načinima rada
- Vrijeme utrošeno na popravke, bojenje i rezervne dijelove na temelju proizvođačevog rasporeda

Fiksna naknada, vrijeme i tablice tarifa dodani su u protokol.

## PROBNA VOŽNJA

Tijekom probne vožnje procjenjuju se mehanički sklopovi vozila. Mogu se naplatiti neispravnosti, ovisno o pravilima navedenim u protokolu.

## Ispitivanje u slobodnom hodu – Brzina za prometnu gužvu

- Uobičajeno pokretanje, na svim cilindrima
- Automatski mjenjač: Provjera blokiranja u položaju "P" na nagibu i bez pokretanja s uključenim stupnjem prijenosa
- Pravilan rad u slobodnom hodu
- Potpuna blokada s lijeva udesno: Mjenjač, sklop prednje osovine, ležajevi itd.
- Upozorenje na zakopčani sigurnosni pojas
- Mehanički zvuk
- Unutarnji zvuk okoline
- Rad sustava klima uređaja
- Ispitivanje GPS-a: Programiranje odredišta

## Faza ubrzanja

- Samo ubrzanje: potpora ispitivanja pogonskog sklopa (silentblok motora), ESP, ASR (ako nije moguće)
- Rad sustava superpunjenja: Turbopunjač – kompresor
- Mjenjač: Uključivanje svih brzina (povećanje, bez lupanja, brza sinkronizacija)
- Mehaničke vibracije: Motor, prijenos, ispuh, polužja itd.

## Faza ubrzanja 50 – 70 km/h

- Ispitivanje amortizera: Sklop prednjeg i stražnjeg polužja na neravnim cestama ili retarderi
- Buka kod vožnje: Ležajevi, deformacije gume
- Kolo upravljača: Poravnanje u točki 0, održavanje i stabilnost održavanja smjera – otpor kola upravljača
- Aerodinamička buka: Usis zraka, zagušenje
- Ispitivanje proklizavanja spojke između 4. i 5. brzine prilikom povećavanja ili smanjivanja brzina
- Ispitivanje GPS-a – prijenos i traženje položaja (prisutnost CD-a)

## Faza usporavanja

- Pritisnuto progresivno kočenje: Učinkovitost, održavanje u traku, vibracije
- Ispitivanje mjenjača: Promjena svih brzina u 2. brzinu
- Ispitivanje uključivanja sustava ABS (brzina 15 – 20 KM/H)
- Ventilacija motora (po završetku ispitivanja)
- Povratak na ispitivanje, prilikom zaustavljanja i od mjesta prekida, mirisi: Kočnice, ulje, ispuh

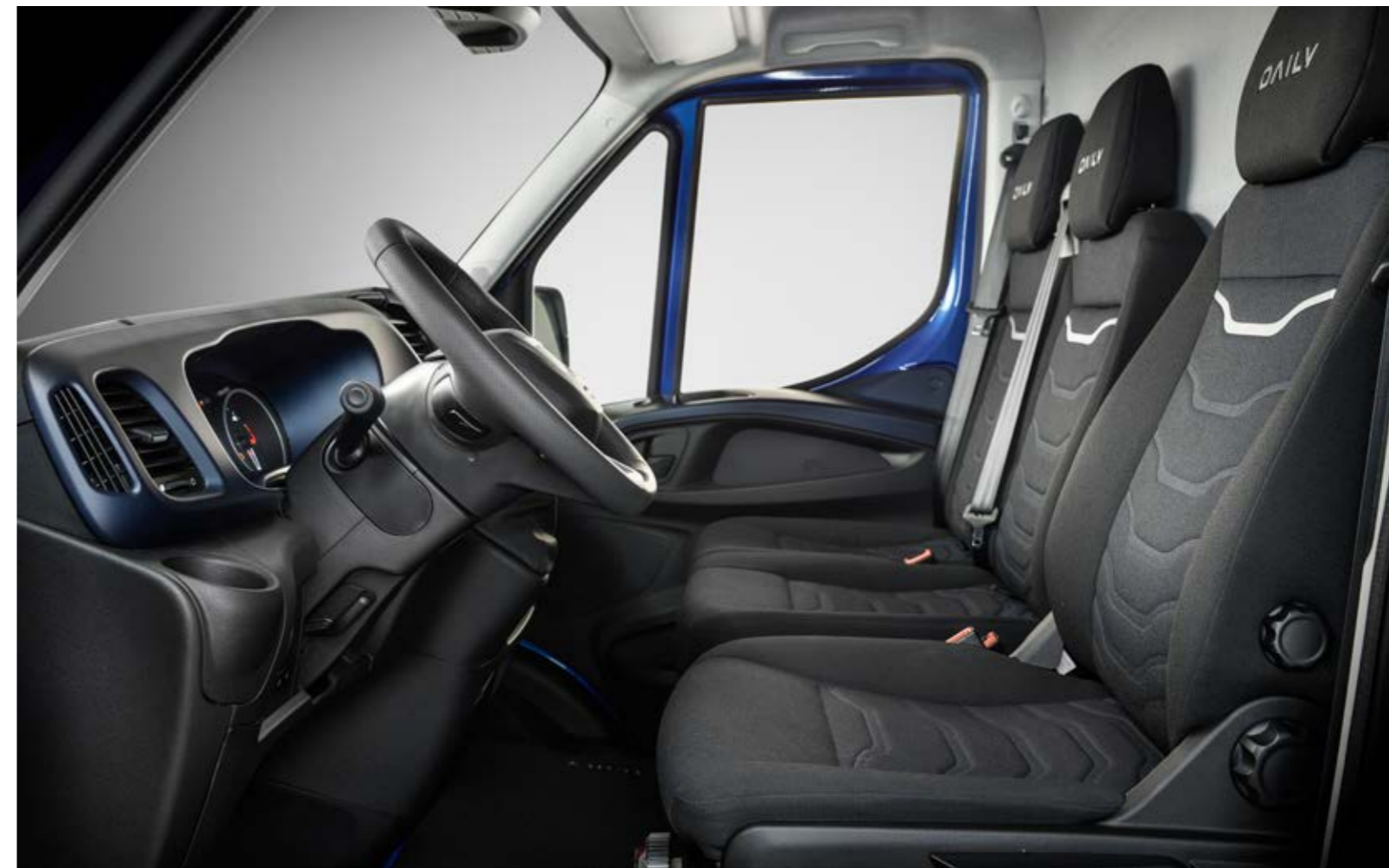

## PROVJERENI DIJELOVI

### Motorni prostor

- Opći izgled: Curenje tekućina, tragovi ulja, korozija, razine vidljive okom,
- Kraj uzdužnih nosača, poprečni nosači hladnjaka i povezani elementi
- Ispitivanje prednjeg kraja
- Akumulator

### Prednji kraj

- Poravnanje dijelova
- Krovni prostor, ravni prednji kraj
- Vjetrobransko staklo
- Poklopac
- Sklopovi svjetla
- Rešetka, prednji branik
- Plašt, aerodinamičko krilce

### Lijeva strana: Vanjski dio

- Poravnanje dijelova
- Prednje krilo
- Koš prednjeg blatobrana i obloga
- Odašiljač prednjeg krila
- Retrovizor
- Vrata
- Podvozje
- Bočne ploče
- Klizma vrata
- Osovina
- Koš stražnjeg blatobrana i obloga
- Prostor krova
- Obloge i krovna obloga
- I svi elementi ili dijelovi koji su sastavni dio vozila

### Stražnji kraj: Otvorena vrata/stražnji kraj

- Prostor krova,
- Graničnik opterećenja
- Stražnji kraj/obloga navlake
- Provjera otvaranja unutarnjih odjeljaka
- Obloga s lijeve i desne strane
- Obloga stražnjeg sjedala
- Oprema za slučaj kvara
- Dijelovi koji se mogu ukloniti: Komplet prve pomoći,

trokut, prsluci, mreže obloga i svi dijelovi povezani s modelom

- Utovarna platforma
- Bočne ploče
- Obloga ploče (originalna, drvena)
- Koš blatobrana
- Krovni prostor, ravni prednji kraj: Kočnice, ulje, ispuh

### Stražnji kraj: Zatvorena vrata/stražnji kraj

- Poravnanje dijelova
- Obloga/stražnji kraj
- Stražnje svjetlo
- Prednja svjetla
- Svjetlo registarske pločice i nosač
- Odbojnik
- Stražnji plašt
- Ispuh (deformacija)
- Stepenica
- Opcija: Rad stražnjeg kraja

### Stražnji kraj: Desna strana

- Poravnanje dijelova
- Prednje krilo
- Koš prednjeg blatobrana i obloga
- Odašiljač prednjeg krila
- Retrovizor
- Vrata
- Podvozje
- Bočne ploče
- Klizma vrata
- Osovina
- Koš stražnjeg blatobrana i obloga
- Prostor krova
- Obloge i krovna obloga
- I svi elementi ili dijelovi koji su sastavni dio vozila

### Kotač, naplatci i rezervni kotač

- Poravnanje dijelova
- Prednje krilo
- Obloga (čelični naplatak)
- Veličina, dimenzije, očitavanje indeksa brzine gume
- Vrsta rezervnog kotača
- Očitavanje istrošenosti gazećeg sloja kotača: Središnji dio, izvana
- Ispitivanje bočne stjenke gume

## Prednja i stražnja sjedala

- Opći izgled vozila: Miris, čistoća, mrlje
- Rad otvora i brava
- Stanje unutarnjeg dijela vrata i ulaza
- Podvozje, pokrovi praga. Vrata brtve
- Staklo, obloga vrata
- Podna obloga
- Rad komandi sjedala, ako je vozilo opremljeno
- Sigurnosni pojas
- Obloge sjedala: sjedište, naslon sjedala i naslon za glavu
- Retrovizor
- Vjetrobransko staklo
- Ploča s instrumentima i konzola
- Krovni prostor, sjenilo za sunce i stropni prostor za odlaganje
- Graničnik opterećenja

## Unutrašnjost: Sjedalo vozača

- Provjera komandi
- Očitavanje kilometraže
- Pokretanje motora i obavijest s bilo kojeg uključenog kontrolnog svjetla upozorenja
- Potpuna blokada kotača za daljnji pregled guma



# TIPKA IKONE



## BOJENJE/POPRAVCI



Način popravka uključuje uklanjanje udubljenja i/ili nanošenje brtvene smjese i/ili brušenje i/ili popravak plastičnog dijela i/ili bojenje.



## ČIŠĆENJE

Kemijski i mehanički postupci, suhi ili vlažni ovisno o mrlji ili tragu prljavštine.



## ZAMJENA

Dijelovi su napuknuti ili loše popravljeni ili je trošak popravka viši od cijene novog rezervnog dijela. Potreban je novi dio.



## NAPOMENA





## SADRŽAJ

---

VANJSKI IZGLED VOZILA	14
PUTNIČKI PROSTOR	32
DODATNE KONSTRUKCIJE	40
TEHNIČKI DETALJI VOZILA	54
OSTALO	62



## **VANJSKI IZGLED VOZILA**



## KAROSERIJA I DODACI: KRHOTINE, OGREBOTINE, UDUBLJENJA, KVAROVI I ČIŠĆENJE

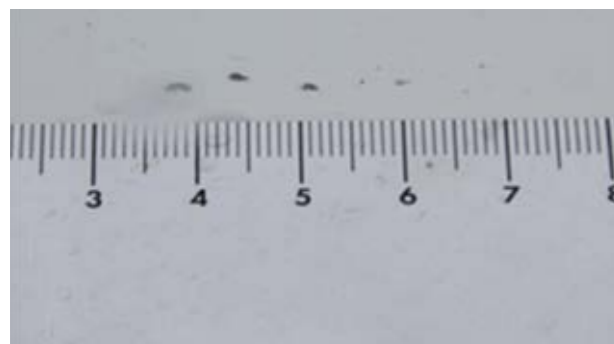

📋 Krhotina  $\leq 5$  mm u promjeru i  $\leq 20$  krhotina



📋 Krhotina na rubu vrata



📋 Oštećenje ili ogrebotina koji se mogu polirati  $\leq 50$  mm

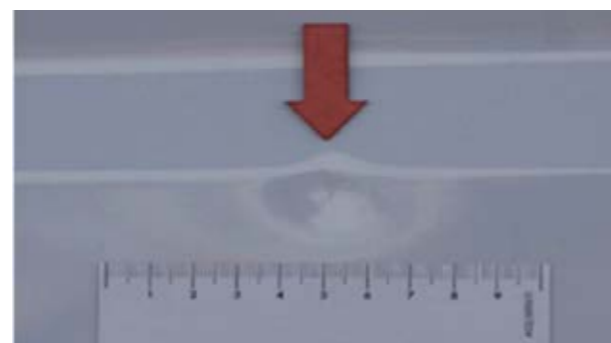

📋 Udubljenja  $\leq 20$  mm u promjeru s neoštećenom bojom, bez oštećenja od tuče i značajnih šupljina s ograničenjem od 5 udubljenja po ploči

### OSTALO:

- 📋 Mali ogrebotine, npr. na rubovima vrata
- 📋 Mali udarci kamena (nema prolaza kroz osnovni premaz) na prednjem dijelu vozila
- 📋 Mala oštećenja nastala zbog zagađenja, mogu se riješiti poliranjem
- 📋 Mali tragovi npr. iz praonice automobila
- 📋 Male ogrebotine boje na rubovima utovara
- 📋 Male razlike u boji zbog upotrebe različitih obloga ili podloga materijali i starenje

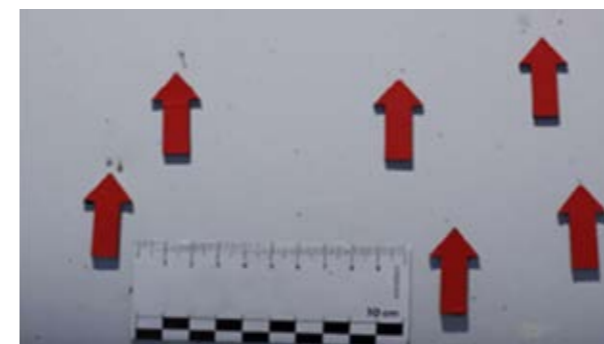

📋 Krhotina  $> 5$  mm ili  $> 20$  krhotina

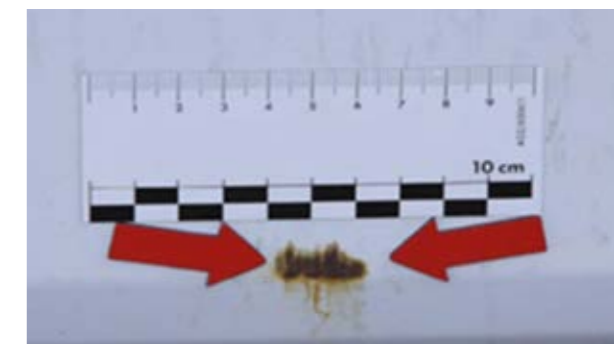

📋 Ogrebotine uz oksidaciju, kemijsko tragovi ili ostalo što se ne može očistiti

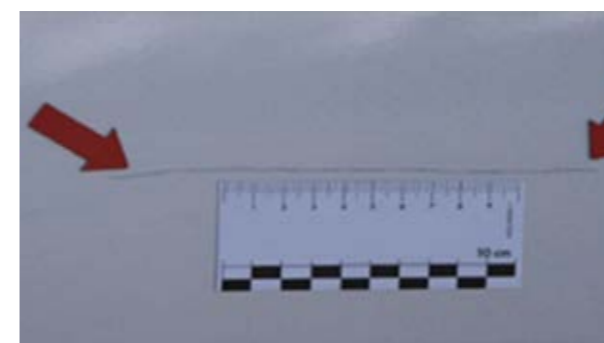

📋 Ogrebotine  $> 20$  mm  
Napomena: Na stražnjim zakretnim vratima ne može bojiti polovica ploče

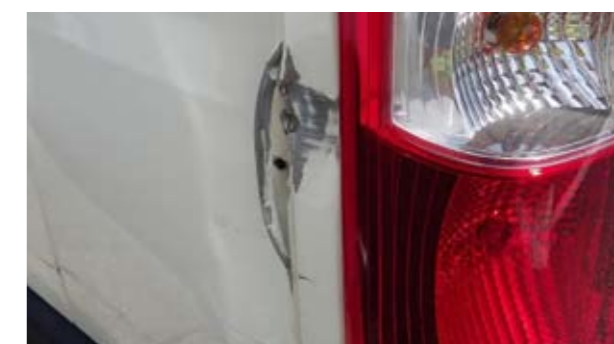



🔄 Dijelovi koji se ne mogu popraviti, ekonomski neisplativ popravak ili neusklađeni zamjenski dio

## KAROSERIJA I DODACI: KRHOTINE, OGREBOTINE, UDUBLJENJA, KVAROVI I ČIŠĆENJE

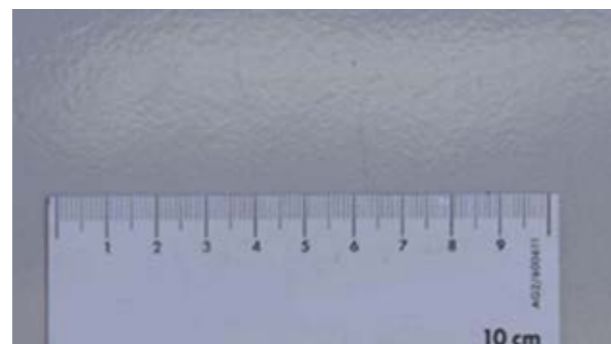

 Udubljenja > 20 mm u promjeru, izmijenjena boja, oštećenje od tuče ili značajne šupljine  
Napomena: Pametni je popravak moguć na izoliranim, većim šupljinama ako boja nije izmijenjena



 Loše obojeno (s mjehurićima). Pregusta boja, nedovoljno bolje, sa česticama



 Razlike u nijansi nakon popravka  
Napomena: Prihvatljivo odstupanje povezano sa starenjem vozila



 Tragovi ljepila. Napomena: Prisutnost oznaka ili natpisa, procjena u stvarnom vremenu tijekom čišćenja i/ili poliranja







 Tragovi koje ostavljaju reklame nakon opisa karoserije.



 Kvar: Deformirana ploča nakon popravka



### OSTALO:

-  Značajno oštećenje zbog zagađenja ili kemijski ostavi, ako je potrebno obnoviti boju
-  Značajna odstupanja boje npr. nakon popravka boje
-  N profesionalni popravci boje
-  Veliki udarci kamena (kroz osnovni premaz)
-  Skidanje materijala i/ili iskrivljenje karoserije i dodataka

## RETROVIZORI, PRISTUP, VRATA, ODBOJNICI, STRAŽNJE I BOČNE ZAŠTITE PODVOZJA



☑ Ogrebotine koje se ne mogu osjetiti pod noktom i površine  $\leq 45 \text{ cm}^2$  (veličina kreditne kartice)

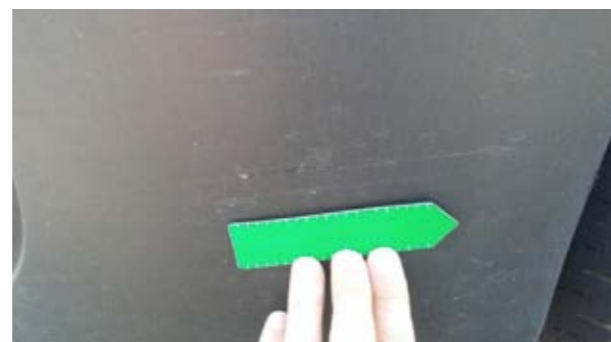

☑ Ogrebotine koje se mogu osjetiti pod noktom ili površine  $\leq 45 \text{ cm}^2$  (veličina kreditne kartice)



☑ Male površinske ogrebotine, npr. na čepu za nadolijevanje goriva, kvakama vrata, odbojnicima i oblogama



☑ Male ogrebotine boje na rubovima utovara

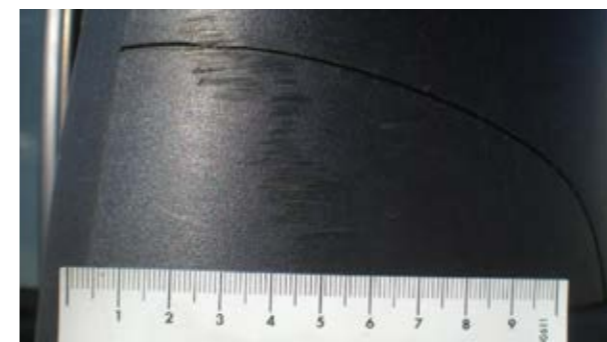

☒ Ogrebotine koje se mogu osjetiti pod noktom ili površine  $> 45 \text{ cm}^2$  (veličina kreditne kartice)



☒ Skidanje materijala ili deformacije koja se može popraviti ili je popravak ekonomski isplativ



☒ Skidanje materijala, razbijeni dio



## RETROVIZORI, PRISTUP, VRATA, ODBOJNICI, STRAŽNJE I BOČNE ZAŠTITE PODVOZJA

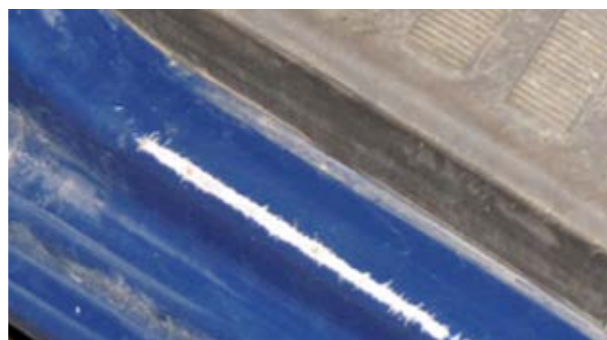

 Ogrebotine koje se mogu osjetiti pod noktom i površine > 45 cm<sup>2</sup> (veličina kreditne kartice)



 Razbijeno, skidanje materijala ili deformacije čiji popravak ekonomski nije isplativ i koji se ne može popraviti





BOJA



POPRAVCI



ČIŠĆENJE



ZAMJENA



NAPOMENA

## OSTAKLJENI DIO I SVJETLA (STRAŽNJA I PREDNJA SVJETLA)



Napomena: Vidno se polje određuje listom papira A3 koji se postavlja okomito na osovину upravljača i centrira okomito na vjetrobransko staklo.

### OSTALO:



Male ogrebotine na stražnjim svjetlima



Mali udarci kamenja na prednjim svjetlima



Udarci kamenja profesionalno popravljeni, ne nalaze se na vozačevom vidnom polju

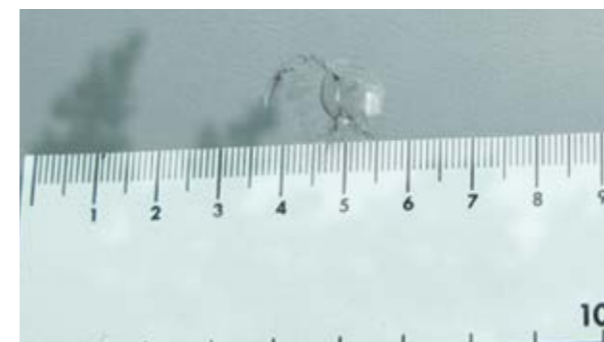

Krhotine  $\leq 20$  mm, izvan vidnog polja i  $\leq 3$  krhotine



Male ogrebotine (bez uklanjanja materijala), izvan područja svjetala i kućišta svjetala (POLIRANJE)



Krhotine  $> 20$  mm, broj  $> 3$  krhotine ili krhotine na vidnom polju, pukotine, slabo postavljeno s greškom, pjeskareno ili ogrebano  
Napomena: Ako je vjetrobransko staklo oštećeno u predjelu vozačevog vidnog polja, treba provjeriti lokalne propise.



## OSTAKLJENI DIO I SVJETLA (STRAŽNJA I PREDNJA SVJETLA)



🔍 Duboke ogrebotine (s uklanjanjem materijala), izvan područja svjetala i zabrtvljenih svjetala



🔄 Razbijena stražnja i prednja svjetla



🔄 Ogrebotine na polju osvjetljenja, pukotine, kondenzacija, puknuće ili puknuto pričvršćenje



## GUME, NAPLATCI I POKROVI KOTAČA



Gume: Utor  $\leq 3$  mm dubine (JE LI U SKLADU?)



Gume: Dubina osnove utora  $\geq 5$  mm (U SKLADU JE)  
Napomena: Istrošenost guma mjeri se na najviše istrošenom utoru gume.



 Naplatci i pokrovi kotača: Više površinskih ogrebotina sa ili bez uklanjanja materijala





 Gume: Utor  $> 3$  mm dubine, skidanje



 Pokrovi kotača: Iskrivljeni, razbijeni, materijal nedostaje ili je skinut



 Gume: Dubina osnove utora  $< 5$  mm  
Napomena: Istrošenost guma mjeri se na najviše istrošenom utoru gume.

 marka gume ne pripada niti jednoj od referentnih marki u nastavku:  
Michelin, Kleber, Continental, Uniroyal, Bridgestone, Firestone, Good-Year, Dunlop, Pirelli, Yokohama, Hankook.

 Prisutnost guma različitih proizvođača na istoj osovini

 Nisu poštivane veličine i oznake proizvođača

 Guma je ponovno narezana ili je promijenjena veličina

## GUME, NAPLATCI I POKROVI KOTAČA



 Na čeličnom naplatku: Pričvrtni rub je malo iskrivljen



 Oštećena je obloga naplatka, neusklađeni naplatak. Provjera dimenzija radi provjere sigurnosti vozila

 Pukotine, iskrivljenja, značajan gubitak materijala, značajno oštećenje boje na naplaticima

 Značajna korozija na naplaticima i na mješovitoj ili zimskoj gumi







## PUTNIČKI PROSTOR

## PRESVLAKE, PODNE OBLOGE, OBLOGE I KROVNI PROSTOR

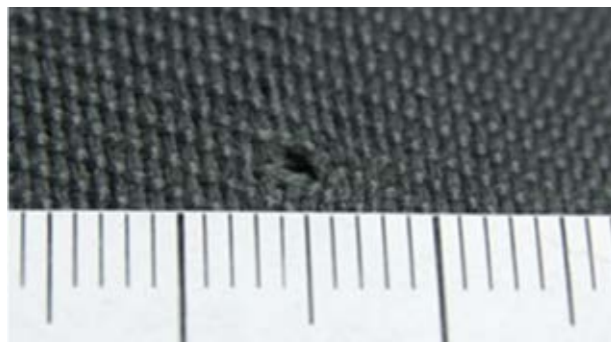

Pregoreno ≤ 3 mm i bez perforacija na pokrovu



Mala se zaprljanja mogu ukloniti profesionalnim kemijskim čišćenja



Malo izbledjena boja zbog sunčevih zraka

Pokidana obloga internog stjenke iza sjedala vozača



Pregoreno > 3 mm, perforacija ili kidanje pokriva, nema oštećenja pjene



Pjena nedostaje ili je okvir razbijen



Perforacije na oblogama tvrde plastike. Za popravak obloga od tvrde plastike potrebno je 1 sat fiksno, ako je to estetski prihvatljivo i može se popraviti

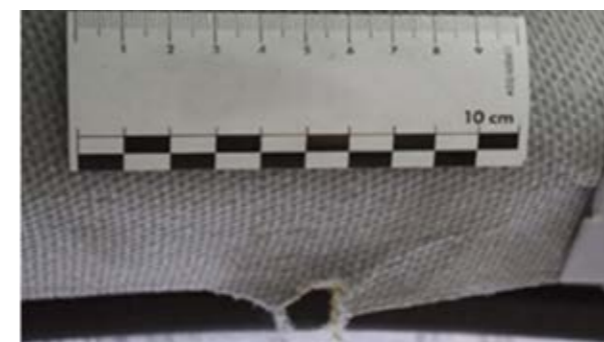

Tkana obloga: Kidanje, rupa > 5 mm, neizbrisivi tragovi



## PRESVLAKE, PODNE OBLOGE, OBLOGE I KROVNI PROSTOR



 Značajno zaprljanje, mrlje i mirisi koje treba profesionalno kemijski očistiti.



 Oprema ili obloge koje nedostaju



## PLOČA S INSTRUMENTIMA, KOLO UPRAVLJAČA, INSTRUMENTI, UPRAVLJAČKI SUSTAVI, GRIJANJE, VENTILACIJA, KLIMATIZACIJA ZRAKA, SAMOSTALNI SUSTAV KLIMA UREĐAJA, DODATNO GRIJANJE





 Tragovi istrošenosti na ploči s instrumentima, sklopu s instrumentima i kolu upravljača



 Malo izblijeđena boja zbog sunčevih zraka

 Mala se zaprljanja mogu ukloniti profesionalnim kemijskim čišćenja



  Nedostaju ili su razbijene ili probušeni upravljački dijelovi, sjedala ili dijelovi obloga

  Sustavi, sigurnosni pojasevi, komande sjedala, zasloni i prikazi ne rade



 Ogrebotine na kombiniranoj ploči s instrumentima i ostalim prikazima ili rupe na vidnom polju



 Značajno zaprljanje, mrlje i mirisi koje treba profesionalno kemijski očistiti.

### OSTALO:

 Tragovi karbonizacije

 Značajno blijeđenje boje

 Začepljeni filtri

 Oštećen pokrov kola upravljača



## **DODATNE KONSTRUKCIJE**

## KOMBI VOZILA



📋 Stražnje stepenice: Malo iskrivljenje



📋 Interni drveni štitnici: Mali udarci



📋 Interne deformacije: Male deformacije bez perforacija ili rezova, vrijeme popravka  $\leq$  3 h



🔧 Stražnje stepenice: Deformacije unutar ekonomski isplativog popravka



🔄 Stražnje stepenice: Deformacije koje ne spadaju u ekonomski isplativ popravak

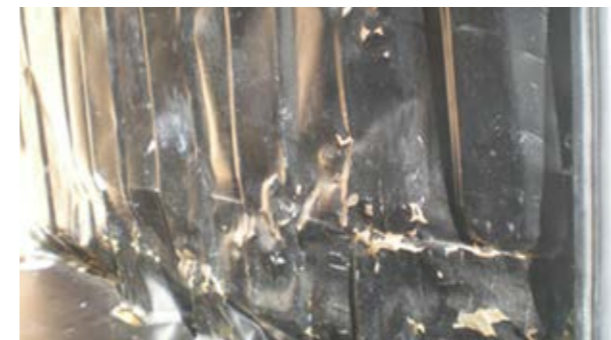

🔄 Interne deformacije: Značajne deformacije, vrijeme popravka  $>$  3 h, perforacije, rezovi



🔄 Interne deformacije: Perforacije, rezovi, deformacije čiji popravak ekonomski nije isplativ. Denaturiranje i neodgovarajući talozi (prašina, boja itd.) (Koš blatobrana ne obnavlja se ako je vrijeme popravka  $<$  3 h)



🔄 Interni drveni štitnici: Udraci, puknuta ploča, ploča koja nedostaje (osim gornjih ploča vrata)

## PODVOZJE 20 M3



☰ Ravni prednji kraj i usmjerivač: Male ogrebotine koje se uklapaju u izgled vozila



☰ Bočne ploče: Male ogrebotine s uklanjanjem materijala  $\leq 20$  cm



☰ Bočni profili podvozja: Male ogrebotine



☰ Nosači bicikla: Male ogrebotine

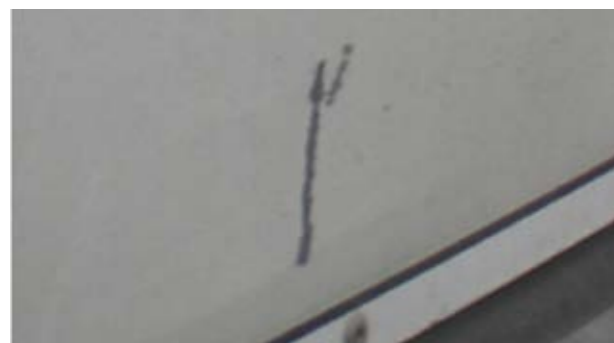

☰ Bočna i stražnja vrata: Malo iskrivljenje: Vrijeme popravka  $\leq 1$  h



☰ Podovi: Malo iskrivljenje, površinska istrošenost

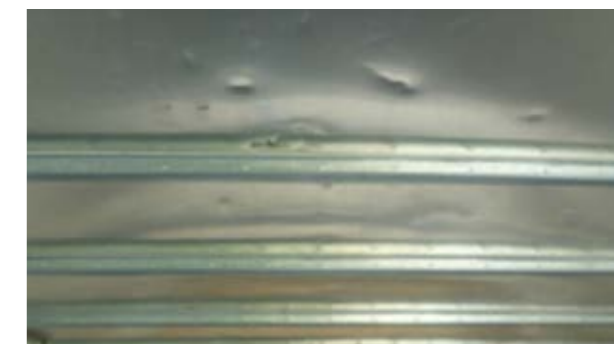

☰ Krovni prostor: Mala iskrivljenja koja se uklapaju u izgled vozila



☰ Navlake i šipke: Tepih je poderan ili odvojen

## PODVOZJE 20 M3



 Ravni prednji kraj i usmjerivač: Unutra ekonomski isplativog popravka



 Ravni prednji kraj i usmjerivač: Značajna pukotina, dio koji ne dostaje ili popravak koji nije ekonomski isplativ



 Bočne ploče: Ogrebotina uz uklanjanje materijala  $\geq 20$  cm unutar ekonomski isplativog popravka.  
Opcija bojenja pola ploče



 Drvene bočne ploče: Oštećeni drveni nosač  $\geq 20$  cm



 Bočni profili podvozja: Deformacije unutar ekonomski isplativog popravka



 Bočne ploče od vlakana: Deformacija donjeg dijela, dužina  $> 1$  m  
Napomena: Prilikom zamjene prednje ploče podvozja treba skinuti podvozje.



 Bočni profili podvozja: Deformacije čiji popravak nije ekonomski isplativ, perforacije, skidanje dijela profila



 Nosači bicikla: Deformacije unutar ekonomski isplativog popravka



 Podizanje stražnjeg kraja: Deformacije platforme unutar ekonomski isplativog popravka



 Nosači bicikla: Deformacije čiji popravak nije ekonomski isplativ





## PODVOZJE 20 M3



Podizanje stražnjeg kraja: Deformacije platforme čiji popravak nije ekonomski isplativ, puknuta ili nepotpuna obloga



Bočna i stražnja vrata: Značajna iskrivljenja: Vrijeme popravka > 1 hunutarekonoski isplativog popravka, zatvaranje nije zabrtvljeno



Bočna i stražnja vrata: Vrata su iskrivljena na pričvršnim točkama šarki, puknuta, perforirani ili popravak nije ekonomski isplativ



Podovi: Deformacije ili perforacije unutar ekonomski isplativog popravka

Deformacije ili perforacije čiji popravak ekonomski nije isplativ. Opcija zamjene dijelova poda



Krovni prostor: Perforiran ili poderan unutar ekonomski isplativog popravka



Podizanje stražnjeg kraja: Istekli datumi kontrole



Krovni prostor: Oštećeni okvir; koža čiji popravak nije ekonomski isplativ



Navlake i šipke: Šipke i navlake iskrivljeni unutar ekonomski isplativog popravka



Navlake i šipke: Šipke, pričvršćenja i navlake nedostaju ili su iskrivljene tako da popravak nije ekonomski isplativ

## KIPERI



 Male ogrebotine, iskrivljenja vodilica s vremenom popravka  $\leq$  1 h



 Ogrebotine  $>$  20 cm

 Iskrivljenja vodilica s vremenom popravka  $>$  1 h unutar ekonomski isplativog popravka



 Iskrivljenja vodilica čiji popravak nije ekonomski isplativ, zatvaranje nije moguće ili nije nepropusno za pijesak







 Tragovi betona ili kemijskih proizvoda prekrivaju  $\geq$  ¼ površine kipera













 Tragovi betona ili kemijskog proizvoda na stražnjem dijelu kabine

## VOZILA S CERADOM



-  Male površinske ogrebotine (mogu se ukloniti čišćenjem)
-  Mala oštećenja zbog zagađenja
-  Mali tragovi npr. iz praonice automobila
-  Male razlike u boji zbog upotrebe različitih obloga ili podloga i starenja



-   Duboke ogrebotine kroz tkaninu
-   Ogrebotine sa značajnim abrazijama
-   Značajna oštećenja zbog zagađenja
-   Označena blijeđenja boja
-   N profesionalni popravci
-   Rezovi na ceradi, otvori ili kukice
-  Ostaci reklamnih naljepnica ili ljepljiva

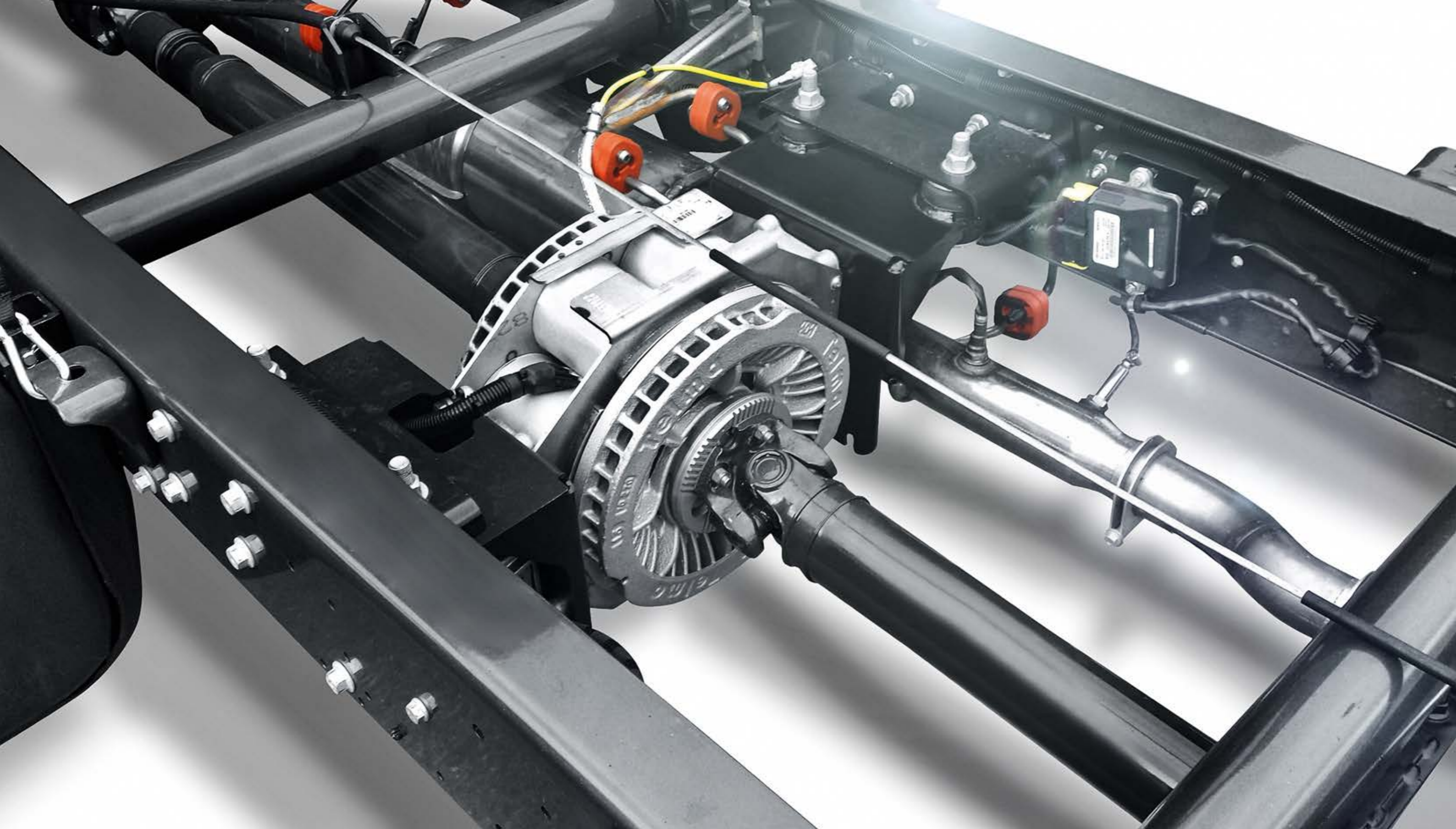

## TEHNIČKI DETALJI VOZILA

## POGONSKI LANAC, UPRAVLJANJE, ŠASIJA, OVJES, SKLOPOVI, DODATNI SKLOPOVI



 Tragovi istrošenosti koji ne ugrožavaju sigurnost na cesti



 Mali tragovi ulja (nema kapanja)









 Sva curenja iz motora, mjenjača i diferencijala, hidrauličkog ovjesa i amortizera



 Curenje iz mjenjača i pumpe servo upravljača

### OSTALO:



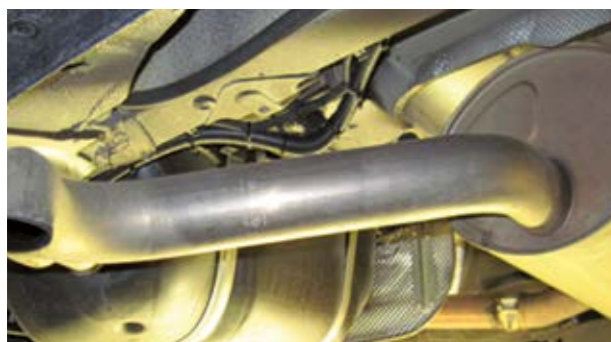

-  Pukotine na kućištu opruge i kućištu osovine mjenjača
-  Puknute opruge
-  Svi tragovi istrošenosti mogu se otkriti vizualnom kontrolom i ne ugrožavaju sigurnost na cesti
-  Dijelovi za osovine, ovjes i šasiju koji su oštećeni udarcima
-  Istrošeni krajnici poluge/poprečni krakovi itd.
-  Neuobičajena buka iz motora, mjenjača, diferencijala i pogonskog lanca

## ISPUŠNI SUSTAV







Uvjeti u skladu s tehničkim pregledom

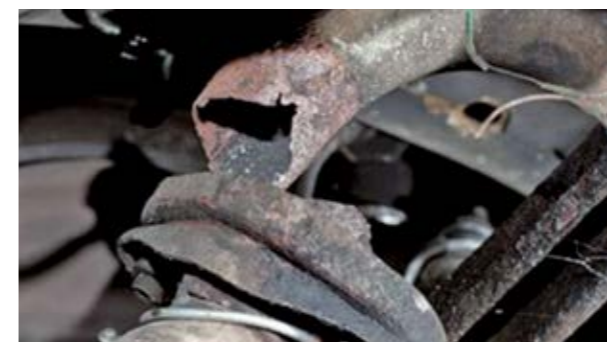

-   Prisutnost curenja
-   Hrđa



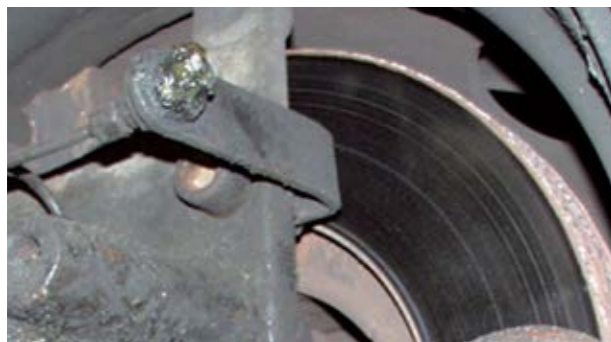

-   Oštećenja zbog vanjskih udaraca
-   Oprema koja nedostaje, npr. poderani ili deformirani izlazi ispuha

## KOČIONI SUSTAV



Uobičajeni uvjeti i u skladu s godištem i kilometražom vozila





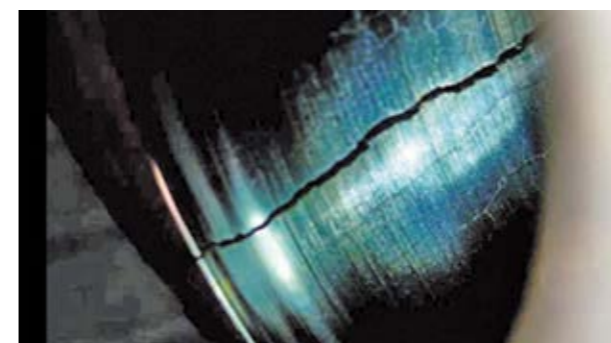





  Hrđavi, prljavi i istrošeni koćioni diskovi



  Nisu u skladu sa zakonom o prometu i nisu valjani prilikom tehničkog pregleda

#### OSTALO:

-   Istrošene obloge kočnice
-   Porozne obloge kočnice
-   Promjena za rad
-   Oštećenje zbog duljeg zaustavljanja

## STANDARDNA OPREMA I DOKUMENTACIJA, ODRŽAVANJE, PREGLEDI



Da biste izbjegli dodatne naknade i troškove, prije povrata vozila provjerite jesu li cijeli svi dijelovi i dokumentacija koja se odnosi na vozilo. Za to upotrijebite sljedeći popis:

- ✓ Servisna knjižica
- ✓ Priručnik u vozilu/korisnički priručnik
- ✓ Potvrda o registraciji
- ✓ Rezervni kotač ili kompresor i proizvod za napuhavanje
- ✓ Komplet alata
- ✓ Uređaj za povlačenje stražnjeg kraja
- ✓ CD/DVD sustava za navigaciju
- ✓ Kodna kartica autoradija (za modele s kodnom karticom)
- ✓ Ključ i rezervni ključ
- ✓ Daljinski upravljač s ključem
- ✓ Trokut upozorenja
- ✓ Razdjelnik prtljage
- ✓ Pokrovi sjedala
- ✓ Ispravnost hladnjaka
- ✓ Kontrola stražnjeg kraja
- ✓ Važeći tehnički pregled

## ČESTA PITANJA

### 1. Što je postupak povrata vozila?

Tri mjeseca prije isteka ugovora dobit ćete pismo ili e-poštu da bi vas se podsjetilo na pravila za povrat vozila i da biste imali vremena za pripremu vozila u skladu s ugovorom.

Dva tjedna prije isteka ugovora mora se organizirati pregled između vas i tvrtke OK TRUCKS, pojedinosti se navode u nastavku.

Na zahtjev ili u slučaju velikog povrata (npr. > 20 jedinica), preliminarni se pregled može organizirati četiri tjedna prije isteka ugovora.

Procjenu oštećenja vodi vanjski dobavljač.

Mjesto povrata: Vozilo se mora vratiti namjesto koje je određeno u uvjetima povrata.

### 2. Što napraviti u slučaju produljenja ugovora ili ako želim kupiti vozilo?

Ako ste zainteresirani za produljenje važećeg ugovora ili kupovinu vozila, obratite se tvrtki IVECO ili svom distributeru u razdoblju od tri do šest mjeseci prije datuma isteka ugovora. Ako se ugovor produljuje, na prodajnom će vas mjestu zatražiti razdoblje i prijedenu kilometražu da bi izračunali ponudu za produljenje.

### 3. Kada moram vratiti vozilo?

Na dan dogovoren s tvrtkom IVECO ili kasnije sve do posljednjeg dana ugovora u skladu s uvjetima povrata.

### 4. Što se događa ako se vozilo vrati nakon isteka ugovora?

Ako se vozilo vrati nakon datuma navedenog u ugovoru, naplaćuje se naknada.

### 5. Što ako vozilo nije u skladu s uvjetima povrata?

Naplaćuju se troškovi popravaka potrebnih za ispunjavanje uvjeta ugovora, osim ako razina oštećenja nije veća od dopuštenog praga u ugovoru o otkupu.

### 6. Što ako se ne slažem s popravcima koji su mi obračunati?

Procjena koju vodi neovisni stručnjak je konačna; ako se s njom ne slažete, možete sami zatražiti procjenu neovisnog stručnjaka o vlastitom trošku.

## OPCIJE UGOVORA

### PRODULJENJE UGOVORA

Ako želite produljiti ugovor, obratite se centru OK TRUCKS na svom području i zatražite sastanak u odjelu rabljenih vozila.

### POVRAT VOZILA

Ako ne dobijemo zahtjev za produljenje ugovora, pretpostavljamo da će nam se roba vratiti na prethodno dogovoren dan isteka ugovora.

Ovaj katalog oštećenja dostupan je i može mu se pristupiti na [www.benussi-cr.oktrucks.com](http://www.benussi-cr.oktrucks.com)



## NAPOMENE

## NAPOMENE

## NAPOMENE

## NAPOMENE

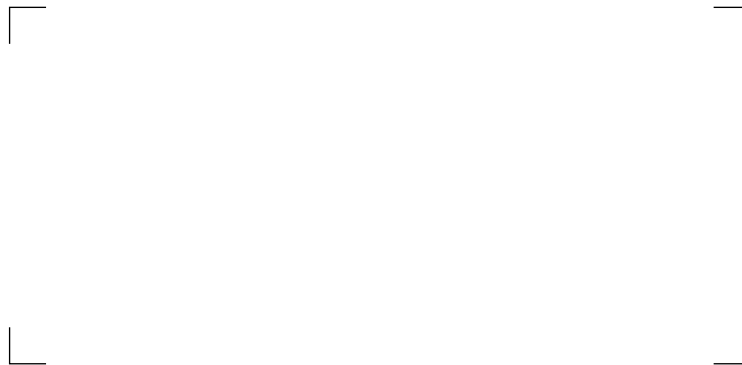

[www.benussi-cr.oktrucks.com](http://www.benussi-cr.oktrucks.com)